

FEIDER
MACHINES

Original Instructions
Ash Vacuum
FHFCA18L-1



BUILDER SAS



32 Rue Aristide Bergès, 31270 CUGNAUX - FRANCE

1



2

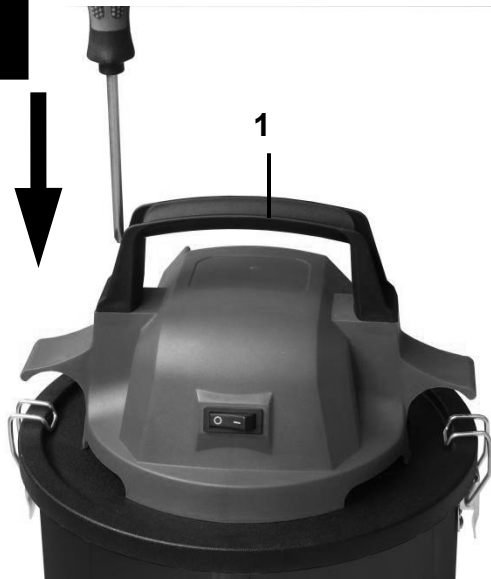

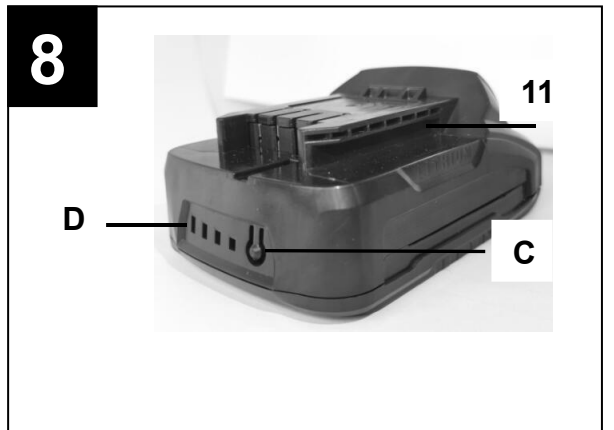
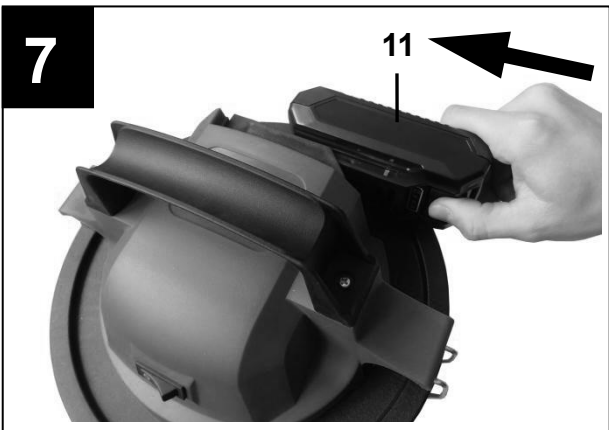
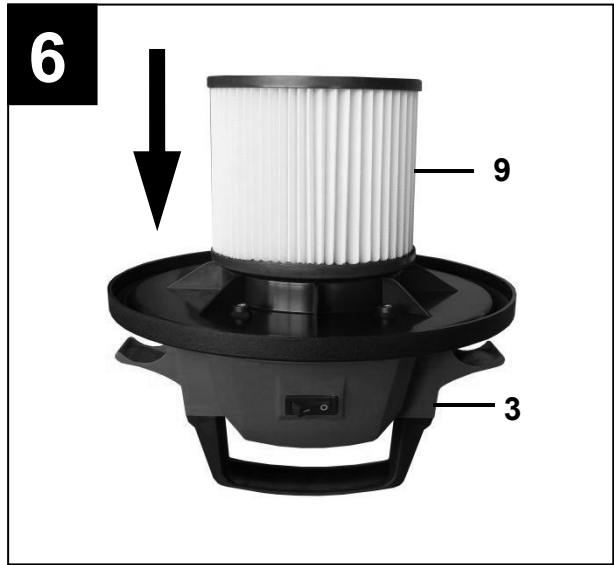
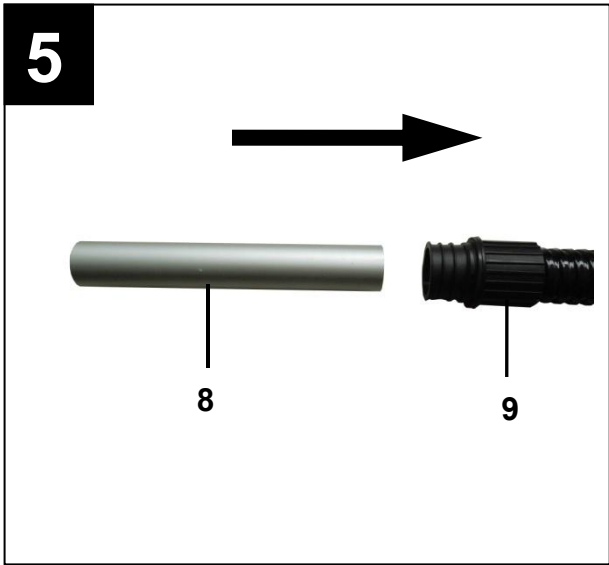
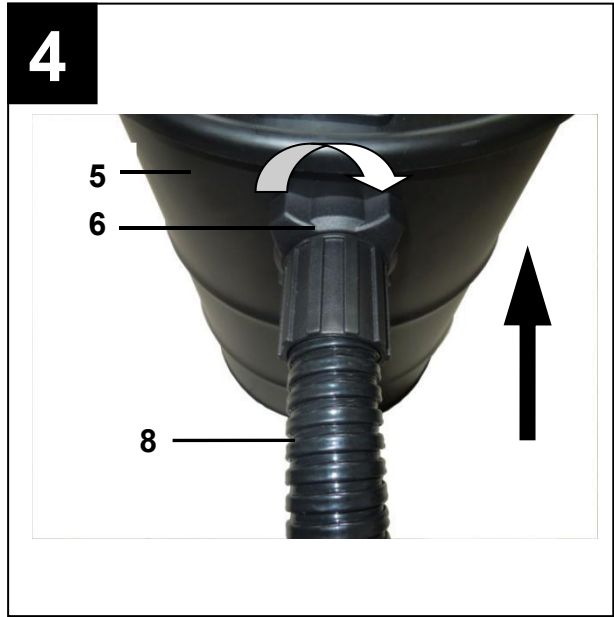
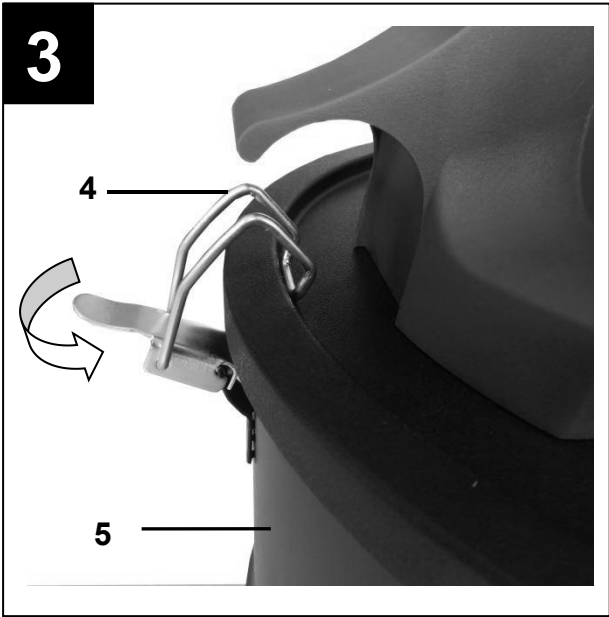



“Caution -

Read the operating instructions to reduce the risk of inquiry”

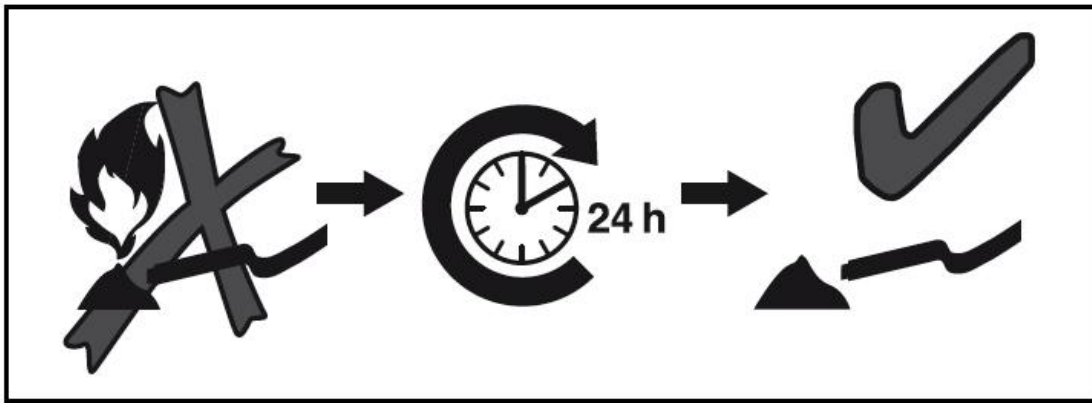

Wait at least 24 hours before vacuuming an oven or a fireplace in order to be sure that the fire has gone out and the ash has cooled down. Only for cold ash, see the operating instructions!



Important!

When using the appliance, a few safety precautions must be observed to avoid injuries and damage. Please read the complete operating instructions with due care. Keep this manual in a safe place, so that the information is available at all times. If you give the appliance to any other person, hand over these operating instructions as well.

We cannot accept any liability for damage or accidents which arise due to a failure to follow these instructions and the safety instructions.

1. Safety regulations



CAUTION

Read all safety regulations and instructions. Any failures made in following the safety regulations and instructions may result in an electric shock, fire and/or serious injury.

Keep all safety regulations and instructions in a safe place for future use.

This appliance can be used by children aged from 8 years and above and persons with reduced physical, sensory or mental capabilities or lack of experience and knowledge if they have been given supervision or instruction concerning use of the appliance in a safe way and understand the hazards involved. Children shall not play with the appliance. Cleaning and user maintenance shall not be made by children without supervision.

- Important: Read the operating instructions before assembling and using the appliance for the first time.
- Check that the mains voltage is the same as the mains voltage specified on the rating plate.
- Never clean the appliance with solvents.
- Never leave the appliance unattended when operational.
- Keep away from children.
- Never vacuum the following: Burning matches, smoldering ash and cigarette butts, combustible, caustic, inflammable or explosive substances, vapour or liquids.
- This appliance is not suitable for vacuuming dust which can be

harmful to health.

- Store the appliance in a dry indoor location.
- Never use the appliance if it is damaged.
- Only allow the appliance to be serviced by an authorized customer service center.
- Only use the appliance to carry out work for which has been designed.
- Use only genuine accessories and spare parts.
- The guidelines in the operating instructions must be observed. The safety and accident-prevention regulations from the lawgiver are also to be observed.
- **Important!** Hazardous material must not be extracted with the ash filter.
- Do not extract ashes from prohibited fuels.
- Do not use the ash filter to extract hot, glowing or inflammable objects (e.g. charcoal, cigarettes ...).
- **Important!** The ash vacuum cleaner is not suitable for vacuuming soot or fine dust.
- **Important!** The extracted material must not exceed a temperature of 40°C.
- **Important!** If this temperature of the extracted material exceeds 40°C, there is a risk of fire.
- **Important!** If the permissible temperature is exceeded, the extractor, the ash filter and the hoses could be damaged.
- **Important!** Extracted material which looks as though it has cooled off on the outside may still be hot on the inside. Hot extracted material could be set alight again in the air current.
- Before beginning extraction, please wait until the material is completely cooled off. Hot ashes should not be purged with water, as the sudden temperature difference can cause ruptures to the chimney.
- Wait at least 24 hours before vacuuming an oven or a fireplace in order to be sure that the fire has gone out and the ash has cooled down.
- Check the hoses, the ash filter and the extractor regularly when extracting, to assess levels of heating.
- “Cold Ash” is ash cooled down for a sufficient time without any pockets of embers inside. This can be confirmed by scouring the ash for pockets of embers by using metal tools before using the ash vacuum cleaner. Cold ash does not emit any recognizable heat.

- After and before vacuum cleaning, empty and clean the tank in order to prevent the accumulation of materials which could present a fire hazard in the vacuum cleaner.
- **Appliance is only to be used with the power supply unit provided with the appliance.**
- **The battery must be removed from the appliance before cleaning or maintaining the appliance.**

BATTERY AND CHARGER SAFETY

- Before using the charger, read all instructions and cautionary markings on the charger, battery pack and the product using the battery pack.
- Keep the battery charger, batteries and the cordless tool out of children's reach.
- Do not use damaged battery chargers.
- Do not use the supplied battery charger to charge other cordless tools.
- This charger is not intended for any uses other than charging rechargeable batteries. Any other use may result in risk of fire, electric shock or electrocution.
- Do not place any object on top of the charger or place the charger on a soft surface that may result in excessive internal heat. Place the charger in a position away from any heat source.
- Do not operate the charger if it has received a sharp blow, been dropped or otherwise damaged in any way. Have it checked by an electrician or power tool repairer.
- Do not disassemble charger. Take it to an electrician or power tool repairer when service or repair is required. Incorrect reassembly may result in a risk of electric shock, electrocution or fire.
- To reduce risk of electric shock, unplug the charger from the outlet before attempting any cleaning. Removing the battery pack will not reduce this risk.
- Never attempt to connect 2 chargers together.
- DO NOT store or use the tool and battery pack in locations where the temperature may reach or exceed 40°C (such as inside sheds or metal buildings in summer).
- The charger is designed to operate on standard household electrical power. Do not attempt to use it on any other voltage!

- The battery pack is not fully charged out of the carton. First read the safety instructions and then follow the charging notes and procedures.
- **In heavy use the battery pack will become warm. Allow the battery pack to cool to room temperature before commencing with the charging.**
- The longest life and best performance can be obtained if the battery pack is charged when the air temperature is between 18 - 24°C. Do not charge the battery pack in an air temperature below 10°C. or above 40°C. This is important and will prevent damage to the battery pack.
- Do not incinerate the battery pack even if it is seriously damaged or is completely worn out. The battery can explode in a fire.
- Never attempt to open the battery pack for any reason. If the plastic housing of the battery pack breaks or cracks, immediately discontinue use and do not recharge.
- During charging, the battery must be placed in a well ventilated area.

2. Area of application

- Substance to be vacuumed - cold ashes from fireplaces, wood/coal stoves, ashtrays, grill

- empty and clean vacuum cleaner before and after vacuuming to avoid the collection of materials that could pose a fire hazard in the vacuum cleaner

Restriction of use

- do not use for the separation of health-hazardous dusts (dust classes L, M, H)

- vacuum only ashes from admissible fuels

- do not vacuum any hot, burning or glowing objects

- do not vacuum any objects that are hotter than > 40 °C

- do not vacuum any flammable substances

3. Layout and items supplied

1 Handle

2 On/Off switch

3 Appliance head

4 Locking hook

5 Tank

6 Suction hose connector

- 7 Suction tube
- 8 Flexible hose
- 9 Cartridge filter
- 10 Charger
- 11 Battery pack
- 12 Push lock button
- 13 Suction hose holder

4. Intended use

The ash vacuum cleaner is suitable for vacuuming cold ash or cold material residues from fireplaces, charcoal ovens, ash-trays or barbecues.

The machine is to be used only for its prescribed purpose. Any other use is deemed to be a case of misuse. The user/operator - not the manufacturer - will be liable for any damage or injuries caused as a result thereof.

Please note that our appliance has not been designed for use in commercial, trade or industrial applications. Our warranty will be voided if the appliance is used in commercial, trade or industrial businesses or for equivalent purposes.

5. Technical data

Voltage supply to motor: 20 V d.c.

Tank volume: 18 L

Weight (without battery): 2.50 kg

Lithium-ion battery

Voltage: 20 V d.c.

Capacity: 2.0 Ah

Charger:

Input voltage: 220 - 240 V ~ 50/60 Hz, 0.6A max

Output voltage: 20 V d.c.

Output current: 2 A

Charging time: 1 hours

6. Before starting the appliance

6.1 Assembling the appliance

- **Fitting the handle (Fig. 2)**

Use a screwdriver to fit the handle (1) with two screws supplied.

- **Fitting the appliance head (Fig. 3)**

The appliance head (3) is fastened to the container (5) by the locking hook (4). To remove the appliance head (3), open the locking hook (4) and remove the appliance head (3). When fitting the appliance head (3), make sure that the locking hook (4) locks into place correctly.

- Plug the vacuum tube (7) onto the end of the suction hose (8).
- Fit the suction hose (8) onto the connection (6) and turn until securely attached.

6.2 Fitting the filter



Important!

Never use the ash vacuum without the filter!
Always ensure that the filters are perfectly secure.

Assembly / Dismantling of the filter (Fig. 6)

- Push the cartridge filter (9) on the appliance head (3) (Fig.6).
- Dismantle the filter in the reverse order.

6.3 Installing the battery (Fig. 7)

Insert the battery pack (11) into the mount and push it forward until you hear the battery engage. To remove the battery pack, press the side push lock button (12) of the battery pack, pull the battery pack away from the mount.

Battery protection system

The tool is equipped with the battery protection system, which helps to ensure a long service life. The output power automatically cuts off during operation when the tool and/or battery are placed under the following situations:

- **When the tool is overloaded:**

If this occurs, release the trigger switch and remove causes of overload, then pull the switch trigger again to restart.

- **When the remaining battery capacity becomes low:**

Recharge the battery pack.

Note: The battery protection system does not in any way damage the tool.

Note: The indicated capacity may be lower than the actual level during use or immediately after using the tool.

6.4 Charging the battery (Fig. 8)

1. Take the battery pack out of the equipment. Do this by pressing the side pushlock buttons.
2. Check that your mains voltage is the same as that marked on the rating plate of the battery charger. Insert the power plug of the charger (10) into the socket outlet. The **RED** LED will then begin to light.
3. Insert the battery pack (11) into the battery charger (10).then the red LED on charger will

begin to **Green flash light**.

4. You will find a label with “Charger indicator” of the LED indicator on the charger.

The battery pack can become a little warm during the charging. This is normal.

If the battery pack fails to charge, check:

- Voltage at the power socket
- Whether there is good contact at the charging contacts.
- Whether the battery pack is warm or not, The battery protection system will not allow the battery to be charged if the battery temperature is over 40°C after use, allow the battery pack to cool to room temperature before commencing with the charging.

If the battery pack still fails to charge, send the charging unit and the battery pack to our customer service center.

To ensure that the battery pack provides long service, you should take care to recharge it promptly. You must recharge the battery pack when you notice that the power of the cordless vacuum drops. Never allow the battery pack to become fully discharged. This will cause it to develop a defect.

6.5 Battery capacity indicator (Fig. 8)

Press the switch for the battery capacity indicator (Fig.8/Item C). The battery capacity indicator shows the charge status of the battery using 4 LEDs (Fig.8/Item D) as following:

All 4 LEDs are lit:

The battery is fully charged.

3 LED(s) are lit:

The battery has approx 75% remaining charge.



2 LED(s) are lit:



The battery has approx 50% remaining charge.

1 LED is lit:

The battery will be empty soon, please recharge the battery.

5.8 Charger indicator

Indicator status	Explanations and actions
	Ready for use The charger is connected to the mains and is ready for use; there is no battery pack in the charger.
	Charging The charger is charging the battery pack in charge mode.

	<p>Battery pack is full of charge. Charging is finished and battery pack in the charger.</p>
	<p>The temperature of battery is too high or too low, the charger is under protection status. The charging function can be recovered after the temperature is normal.</p>
	<p>Unrecoverable battery malfunction.</p>

7. Operation

7.1 ON/OFF switch (Fig. 1)

Press the ON/OFF switch (2) to switch the equipment ON and OFF.



Important!

The ash vacuum cleaner is not suitable for the vacuuming of combustible materials!

8. Cleaning, maintenance and ordering of spare parts



Important!

Always pull out the mains power plug before starting any cleaning work.

8.1 Cleaning



Keep all safety devices, air vents and the motor housing free of dirt and dust as far as possible.



We recommend that you clean the appliance immediately after you use it.

8.2 Cleaning the appliance head (3)

Clean the appliance regularly with a damp cloth and some soft soap. Do not use cleaning agents or solvents; these may be aggressive to the plastic parts in the appliance.

8.3 Cleaning the container (5)

The container can be cleaned with a damp cloth and some soft soap or under running water, depending on the amount of dirt.

8.4 Cleaning the filter (9)

Clean the cartridge filter (9) , e.g. by tapping and brushing or by blowing out with compressed air at low pressure.

8.5 Servicing

At regular intervals and before each use, check that the filters in the ash vacuum are securely fitted.

8.6. Ordering spare parts

Please provide the following information on all orders for spare parts:

- Model/type of the appliance
- Part number of the required spare part

9. Storage

Store the equipment and accessories in a dark and dry place at above freezing temperature. The ideal storage temperature is between 5 and 30°C. Store the electric tool in its original packaging.

10. Trouble-shooting

If the vacuum vibrates abnormally, stop motor immediately. Abnormal vibration usually indicates a mechanical problem, continued operation could lead to injury or damage.

Note: The distributor will not be responsible for any damage or injuries caused by the repair of the vacuum by an unauthorized person or by mishandling of the vacuum. This tool is designed for DIY use - use in commercial or industrial environments will void the warranty.

Symptom	Possible Causes	Corrective Action
Vacuum is not starting	Battery is low in charge	Charge battery
	Battery is not inserted properly	Insert battery pack correctly
	Possible clogging	Empty the debris tank and clean the filter
Vacuum is not operating at full capacity	Debris tank is full	Empty the debris tank
	Filter is clogged	Clean/replace the filter
	Nozzle/ hose is blocked	Check, and clean the nozzle/hose
	Battery is low in charge	Charge battery
Motor stops while vacuuming	Battery has no power	Charge the battery
The battery pack fails to charge	No good contact at the charging contacts.	Repeat the charging action: Insert the power plug of the charger into the socket outlet, Insert the battery pack into the battery charger
	The battery pack is warm	Allow the battery pack to cool to room

	<p>or not, The battery protection system will not allow the battery to be charged if the battery temperature is over 40°C after use.</p>	<p>temperature before commencing with the charging.</p>
--	--	---

11. Disposal and recycling



For EU countries only

Never place any electric power tools in your household refuse.

To comply with European Directive 2012/19/EU concerning old electric and electronic equipment and its implementation in national laws, old electric power tools have to be separated from other waste and disposed of in an environment-friendly fashion, e.g. by taking to a recycling depot.

Recycling alternative to the return request:

As an alternative to returning the equipment to the manufacturer, the owner of the electrical equipment must make sure that the equipment is properly disposed of if he no longer wants to keep the equipment. The old equipment can be returned to a suitable collection point that will dispose of the equipment in accordance with the national recycling and waste disposal regulations. This does not apply to any accessories or aids without electrical components supplied with the old equipment.